

Received
July 29 2022
Cross Connection

41-05200

RT53 WATER INC.

**RESOLUTION 22-1
(Board of Directors)**

To adopt and enable the enforcement of state cross connection control requirements by RT53 WATER INC, we, the Board of Directors of RT53 WATER INC, formally RESOLVE to amend RESOLUTION 17-1 by adding subsection 1.a. as set forth below:

1.a. Cross Connection Control Requirements. Oregon Administrative Rule (OAR) 333-061-0070 is hereby adopted and incorporated herein, as shown in Exhibit A, attached hereto. As used therein; "water supplier" shall refer to RT53 WATER INC, and "water user" or "premises owner" shall refer to RT53 WATER INC members. RT53 WATER INC and all members shall comply with the requirements set forth in Oregon Administrative Rule (OAR) 333-061-0070.

Duly adopted by the Board of Directors at the annual meeting held on the 23rd day of July, 2022.



Ron Olson
Director

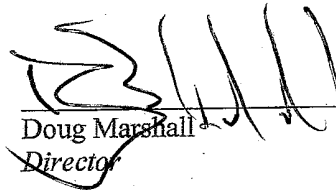

Doug Marshall
Director

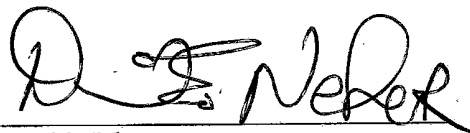

David Neher
Director

(Absent)

Tim Troutman
Director

(Absent)

Tim Wolden
Director

OAR 333-061-0070**Cross Connection Control Requirements**

- (1) Water suppliers shall undertake cross connection control programs to protect the public water systems from pollution and contamination.
- (2) For the purposes of this rule, the following definitions apply:
 - (a) "Pollutant" means a substance that creates an impairment of the quality of the water to a degree which does not create a hazard to the public health, but which does adversely affect the aesthetic qualities of the water.
 - (b) "Thermal expansion" means the pressure increase due to a rise in water temperature that occurs in water piping systems when such systems become "closed" by the installation of a backflow prevention assembly or other means, and will not allow for expansion beyond that point of installation.
- (3) The water supplier's responsibility for cross connection control shall begin at the water supply source, include all public treatment, storage, and distribution facilities under the water supplier's control, and end at the POD to the water user's premises.
- (4) Water suppliers shall develop and implement cross connection control programs that meet the minimum requirements set forth in these rules.
- (5) Water suppliers shall develop a procedure to coordinate cross connection control requirements with the appropriate local administrative authority having jurisdiction.
- (6) The water supplier shall ensure that inspections of approved air gaps, approved devices, and inspections and tests of approved backflow prevention assemblies protecting the public water system are conducted:
 - (a) At the time of installation, any repair or relocation;
 - (b) At least annually;
 - (c) More frequently than annually for approved backflow prevention assemblies that repeatedly fail, or are protecting health hazard cross connections, as determined by the water supplier;
 - (d) After a backflow incident; or
 - (e) After an approved air gap is re-plumbed.
- (7) Approved air gaps, approved devices, or approved backflow prevention assemblies, found not to be functioning properly shall be repaired, replaced or re-plumbed by the water user or premises owner, as defined in the water supplier's local ordinance or enabling authority, or the water supplier may take action in accordance with subsection (9)(a) of these rules.
- (8) A water user or premises owner who obtains water from a water supplier must notify the water supplier if they add any chemicals or substance to the water.
- (9) Premises isolation requirements:
 - (a) For service connections to premises listed or defined in Table 42 (Premises Requiring Isolation), the water supplier shall ensure an approved backflow prevention assembly or an approved air gap is installed;
 - (A) Premises with cross connections not listed or defined in Table 42 (Premises Requiring Isolation), shall be individually evaluated. The water supplier shall require the installation of an approved backflow prevention assembly or an approved air gap commensurate with the degree of hazard on the premises, as defined in Table 43 (Backflow Prevention Methods);

- (B) In lieu of premise isolation, the water supplier may accept an in-premises approved backflow prevention assembly as protection for the public water system when the approved backflow prevention assembly is installed, maintained and tested in accordance with these rules.
- (b) Where premises isolation is used to protect against a cross connection, the following requirements apply;
 - (A) The water supplier shall:
 - (i) Ensure the approved backflow prevention assembly is installed at a location adjacent to the service connection or POD;
 - (ii) Ensure any alternate location used must be with the approval of the water supplier and must meet the water supplier's cross connection control requirements; and
 - (iii) Notify the premises owner and water user, in writing, of thermal expansion concerns.
 - (B) The premises owner shall:
 - (i) Ensure no cross connections exist between the POD from the public water system and the approved backflow prevention assemblies, when these are installed in an alternate location; and
 - (ii) Assume responsibility for testing, maintenance, and repair of the installed approved backflow prevention assembly to protect against the hazard.
- (c) Where unique conditions exist, but not limited to, extreme terrain or pipe elevation changes, or structures greater than three stories in height, even with no actual or potential health hazard, an approved backflow prevention assembly may be installed at the POD; and
- (d) Where the water supplier chooses to use premises isolation by the installation of an approved backflow prevention assembly on a one- or two-family dwelling under the jurisdiction of the Oregon Plumbing Specialty Code and there is no actual or potential cross connection, the water supplier shall:
 - (A) Install the approved backflow prevention assembly at the POD;
 - (B) Notify the premises owner and water user in writing of thermal expansion concerns; and
 - (C) Take responsibility for testing, maintenance and repair of the installed approved backflow prevention assembly.
- (10) In community water systems, water suppliers shall implement a cross connection control program directly, or by written agreement with another agency experienced in cross connection control. The local cross connection program shall consist of the following elements:
 - (a) Local ordinance or enabling authority that authorizes discontinuing water service to premises for:
 - (A) Failure to remove or eliminate an existing unprotected or potential cross connection;
 - (B) Failure to install a required approved backflow prevention assembly;
 - (C) Failure to maintain an approved backflow prevention assembly; or

- (D) Failure to conduct the required testing of an approved backflow prevention assembly.
- (b) A written program plan for community water systems with 300 or more service connections shall include the following:
 - (A) A list of premises where health hazard cross connections exist, including, but not limited to, those listed in Table 42 (Premises Requiring Isolation);
 - (B) A current list of certified cross connection control staff members;
 - (C) Procedures for evaluating the degree of hazard posed by a water user's premises;
 - (D) A procedure for notifying the water user if a non-health hazard or health hazard is identified, and for informing the water user of any corrective action required;
 - (E) The type of protection required to prevent backflow into the public water supply, commensurate with the degree of hazard that exists on the water user's premises, as defined in Table 43 (Backflow Prevention Methods);
 - (F) A description of what corrective actions will be taken if a water user fails to comply with the water supplier's cross connection control requirements;
 - (G) Current records of approved backflow prevention assemblies installed, inspections completed, backflow prevention assembly test results on backflow prevention assemblies and verification of current Backflow Assembly Tester certification; and
 - (H) A public education program about cross connection control.
- (c) The water supplier shall prepare and submit a cross connection control Annual Summary Report to the Authority, on forms provided by the Authority, before the last working day of March each year.
- (d) In community water systems having 300 or more service connections, water suppliers shall ensure at least one person is certified as a Cross Connection Control Specialist, unless specifically exempted from this requirement by the Authority.
- (11) Fees: Community water systems shall submit to the Authority an annual cross connection program implementation fee, based on the number of service connections, as follows:

Service Connections —	Fee:
15-99 —	\$30.
100-999 —	\$75.
1,000-9,999 —	\$200.
10,000 or more —	\$350.

 - (a) Billing invoices will be mailed to water systems in the first week of November each year and are due by January first of the following year;
 - (b) Fees are payable to Oregon Health Authority by check or money order;
 - (c) A late fee of 50 percent of the original amount will be added to the total amount due and will be assessed after January 31 of each year.

- (12) In transient or NTNC water systems, the water supplier that owns or operates the system shall:
- (a) Ensure no cross connections exist, or are isolated from the potable water system with an approved backflow prevention assembly, as required in section (13) of this rule;
 - (b) Ensure approved backflow prevention assemblies are installed at, or near, the cross connection; and
 - (c) Conduct an annual cross connection survey and inspection to ensure compliance with these rules, and test all backflow assemblies annually. All building permits and related inspections are to be made by the Department of Consumer and Business Services, Building Codes Division, as required by ORS 447.020.
- (13) Approved backflow prevention assemblies and devices required under these rules shall be approved by the University of Southern California, Foundation for Cross-Connection Control and Hydraulic Research, or other equivalent testing laboratories approved by the Authority.
- (14) Backflow prevention assemblies installed before the effective date of these rules that were approved at the time of installation, but are not currently approved, shall be permitted to remain in service provided the assemblies are not moved, the piping systems are not significantly remodeled or modified, the assemblies are properly maintained, and they are commensurate with the degree of hazard they were installed to protect. The assemblies must be tested at least annually and perform satisfactorily to the testing procedures set forth in these rules.
- (15) Tests performed by Authority-certified Backflow Assembly Testers shall be in conformance with procedures established by the University of Southern California, Foundation for Cross Connection Control and Hydraulic Research, Manual of Cross-Connection Control, 10th Edition, or other equivalent testing procedures approved by the Authority.
- (16) Backflow prevention assemblies shall be tested by Authority-certified Backflow Assembly Testers, except as otherwise provided for journeyman plumbers or apprentice plumbers in OAR 333-061-0072 of these rules (Backflow Assembly Tester Certification). The Backflow Assembly Tester must produce three copies of all test reports. One copy must be maintained in the Tester's permanent records, one copy must be provided to the water user or property owner, and one copy must be provided to the water supplier.
- (a) Test reports must be provided within 10 working days; and
 - (b) The test reports must be in a manner and form acceptable to the water supplier.
- (17) All approved backflow prevention assemblies subject to these rules shall be installed in accordance with OAR 333-061-0071 and the Oregon Plumbing Specialty Code.
- (18) The Authority shall establish an advisory board for cross connection control issues consisting of not more than nine members, and including representation from the following:
- (a) Oregon licensed Plumbers;
 - (b) Authority certified Backflow Assembly Testers;

- (c) Authority certified Cross Connection Specialists;
- (d) Water Suppliers;
- (e) The general public;
- (f) Authority certified Instructors of Backflow Assembly Testers or Cross Connection Specialists;
- (g) Backflow assembly manufacturers or authorized representatives;
- (h) Engineers experienced in water systems, cross connection control or backflow prevention; and
- (i) Oregon certified Plumbing Inspectors.

Table 42

High Hazard Table (Premises Requiring Isolation* by an Approved Air Gap or a Reduced Pressure Principle Type of Assembly Health Hazard)
Agricultural (for example, farms, dairies)
Beverage bottling plants**
Car washes
Chemical plants
Commercial laundries and dry cleaners
Premises where both reclaimed and potable water are used
Film processing plants
Food processing plants
Medical centers (for example, hospitals, medical clinics, nursing homes, veterinary clinics, dental clinics, blood plasma centers)
Premises with irrigation systems that use the water supplier's water with chemical additions (for example, parks, playgrounds, golf courses, cemeteries, housing estates)
Laboratories
Metal plating industries
Mortuaries
Petroleum processing or storage plants
Piers and docks
Radioactive material processing plants and nuclear reactors
Wastewater lift stations and pumping stations
Wastewater treatment plants
Premises with piping under pressure for conveying liquids other than potable water and the piping is installed in proximity to potable water piping
Premises with an auxiliary water supply that is connected to a potable water supply
Premises where the water supplier is denied access or restricted access for survey
Premises where the water is being treated by the addition of chemical or other additives

* Refer to OAR 333-061-0070(8) premises isolation requirements.

** A DC could be used if the water supplier determines there is only a non-health hazard at a beverage bottling plant.

Table 43

Backflow Prevention Methods Used For Premises Isolation	
DEGREE OF IDENTIFIED HAZARD	
Non-Health Hazard, Low Risk (Pollutant)	Health Hazard, High Risk (Contaminant)

Backsiphonage or Backpressure	Backsiphonage or Backpressure
Air Gap	Air Gap
Reduced Pressure Principle Backflow Prevention Assembly (RP)	Reduced Pressure Principle Backflow Prevention Assembly (RP)
Reduced Pressure Principle-Detector Backflow Prevention Assembly (RPDA)	Reduced Pressure Principle-Detector Backflow Prevention Assembly (RPDA)
Double Check Valve Backflow Prevention Assembly (DC)	
Double Check-Detector Backflow Prevention Assembly (DCDA)	

Stat. Auth.: ORS 448.131

Stats. Implemented: ORS 448.131, 448.150, 448.278 & 448.279

333-061-0071

Backflow Prevention Assembly Installation and Operation Standards

- (1) Any approved backflow prevention assembly required by OAR 333-061-0070 shall be installed in a manner that:
 - (a) Facilitates its proper operation, maintenance, inspection, and in-line testing using standard installation procedures approved by the Authority, such as, but not limited to, University of Southern California, Manual of Cross-Connection Control, 10th Edition, the Pacific Northwest Section American Water Works Association, Cross Connection Control Manual, 7th Edition, or the local administrative authority having jurisdiction;
 - (b) Precludes the possibility of continuous submersion of an approved backflow prevention assembly, and precludes the possibility of any submersion of the relief valve on a RP; and
 - (c) Maintains compliance with all applicable safety regulations and the Oregon Plumbing Specialty Code.
- (2) For premises isolation installation:
 - (a) The approved backflow prevention assembly shall be installed at a location adjacent to the service connection or POD; or
 - (b) Any alternate location must be with the advance approval of the water supplier and must meet the water supplier's cross connection control requirements; and
 - (c) The premises owner shall ensure no cross connections exist between the POD from the public water system and the approved backflow prevention assembly.
- (3) Bypass piping installed around any approved backflow prevention assembly must be equipped with an approved backflow prevention assembly to:
 - (a) Afford at least the same level of protection as the approved backflow prevention assembly being bypassed; and
 - (b) Comply with all requirements of these rules.
- (4) All Oregon Plumbing Specialty Code approved residential multi-purpose fire suppression systems constructed of potable water piping and materials do not require a backflow prevention assembly.

- (5) Stand-alone fire suppression systems, being a piping system within a premises intended to only serve as a fire protection system separated from the potable water system, shall be protected commensurate with the degree of hazard, as defined in Table 43 (Backflow Prevention Methods).
- (6) Stand-alone irrigation systems shall be protected commensurate with the degree of hazard, as defined in Table 43 (Backflow Prevention Methods).
- (7) A RP or RPDA:

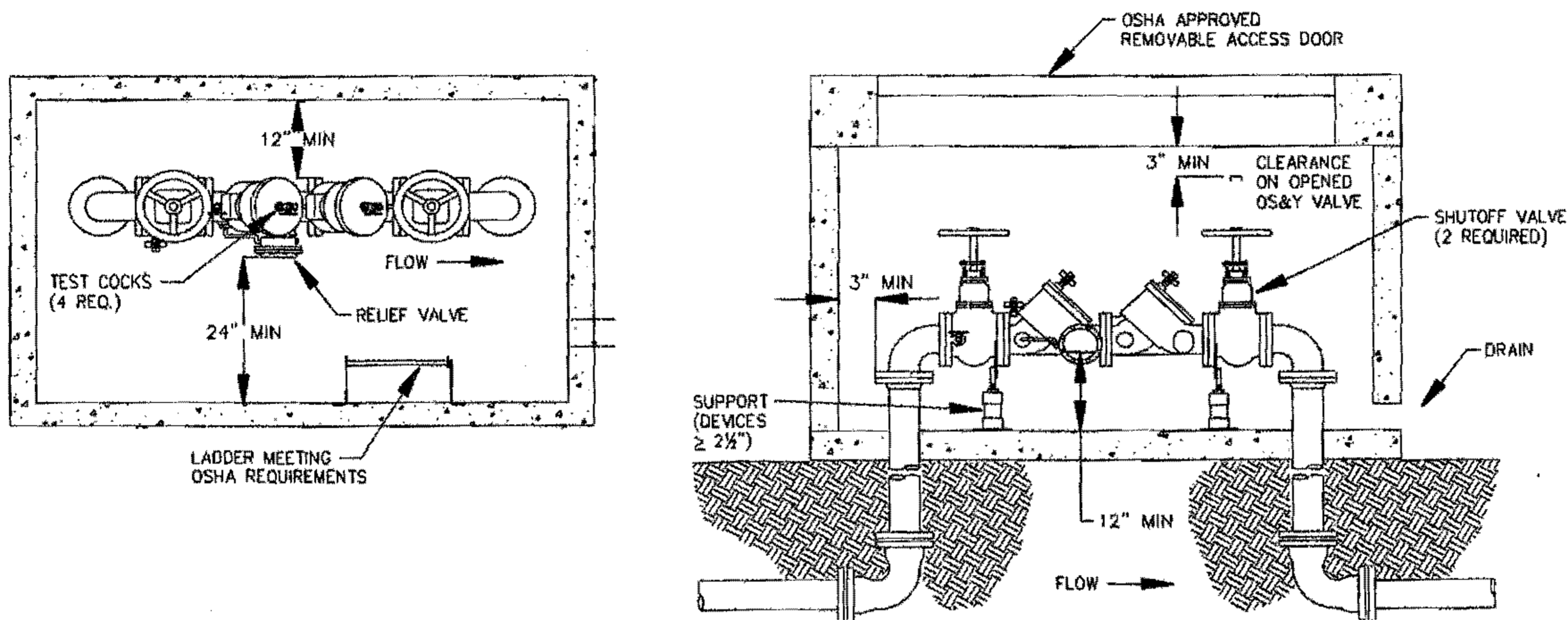

- (a) Shall conform to bottom and side clearances when the assembly is installed inside a building. Access doors may be provided on the top or sides of an above-ground vault;
- (b) Shall always be installed horizontally, never vertically, unless they are specifically approved for vertical installation;
- (c) Shall always be installed above the 100 year (1 percent) flood level unless approved by the appropriate local administrative authority having jurisdiction;
- (d) Shall never have extended or plugged relief valves;
- (e) Shall be protected from freezing when necessary;
- (f) Shall be provided with an approved air gap drain;
- (g) Shall not be installed in an enclosed vault or box unless a bore-sighted drain to daylight is provided where there is an unrestricted straight-line opening in the enclosure that vents to grade, and is sized and constructed to adequately drain the full flow discharge from the reduced pressure principle backflow prevention assembly thus preventing any potential for submersion of the assembly;
- (h) May be installed with reduced clearances if the pipes are two inches in diameter or smaller, are accessible for testing and repairing, and approved by the appropriate local administrative authority having jurisdiction;
- (i) Shall not be installed at a height greater than five feet unless there is a permanently installed platform meeting Oregon Occupational Safety and Health Administration (OR-OSHA) standards to facilitate servicing the assembly; and

- (j) Be used to protect against a non-health hazard or health hazard for backsiphonage or backpressure conditions.
- (8) A DC or DCDA:

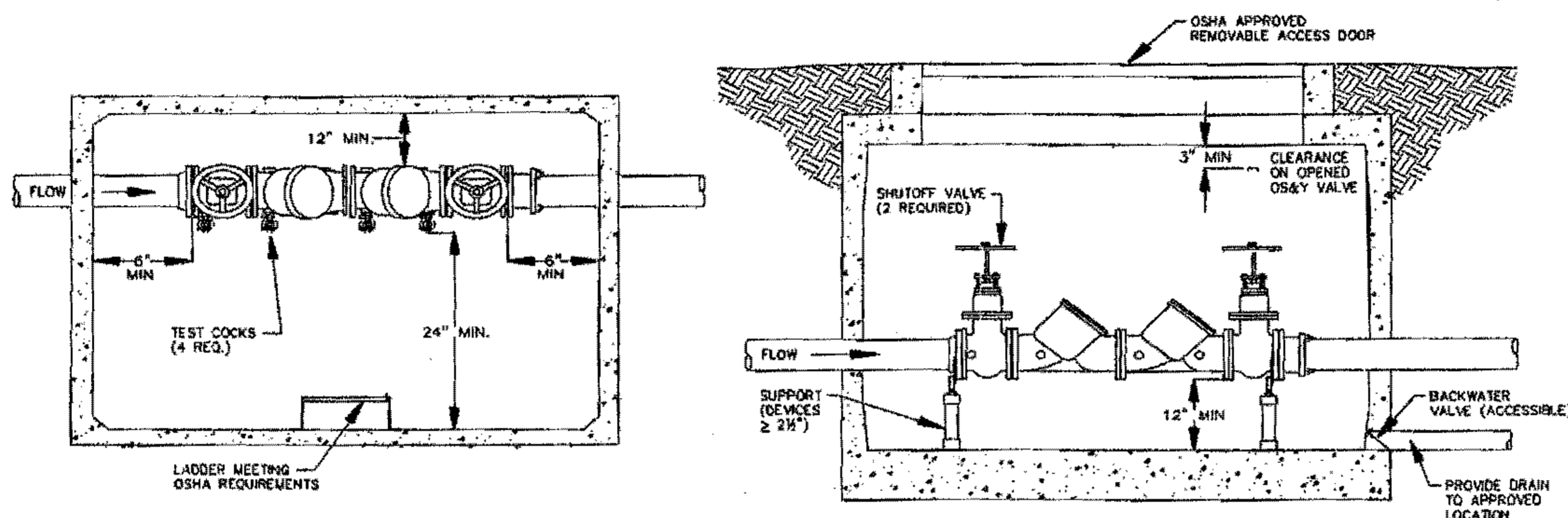

- (a) Shall conform to bottom and side clearances when the assembly is installed inside a building;
 - (b) May be installed vertically as well as horizontally provided the assembly is specifically listed for that orientation in the Authority's Approved Backflow Prevention Assembly List.
 - (c) May be installed below grade in a vault, provided that water-tight fitted plugs or caps are installed in the test cocks, and the assembly shall not be subject to continuous immersion;
 - (d) Shall not be installed at a height greater than five feet unless there is a permanently installed platform meeting Oregon Occupational Safety and Health Administration (OR-OSHA) standards to facilitate servicing the assembly;
 - (e) May be installed with reduced clearances if the pipes are two inches in diameter or smaller, provided that they are accessible for testing and repairing, and approved by the appropriate local administrative authority having jurisdiction;
 - (f) Shall have adequate drainage provided except that the drain shall not be directly connected to a sanitary or storm water drain. Installers shall check with the water supplier and appropriate local administrative authority having jurisdiction for additional requirements;
 - (g) Shall be protected from freezing when necessary; and
 - (h) Be used to protect against non-health hazards under backsiphonage and backpressure conditions.
- (9) A PVB or SVB shall:

Figure 3

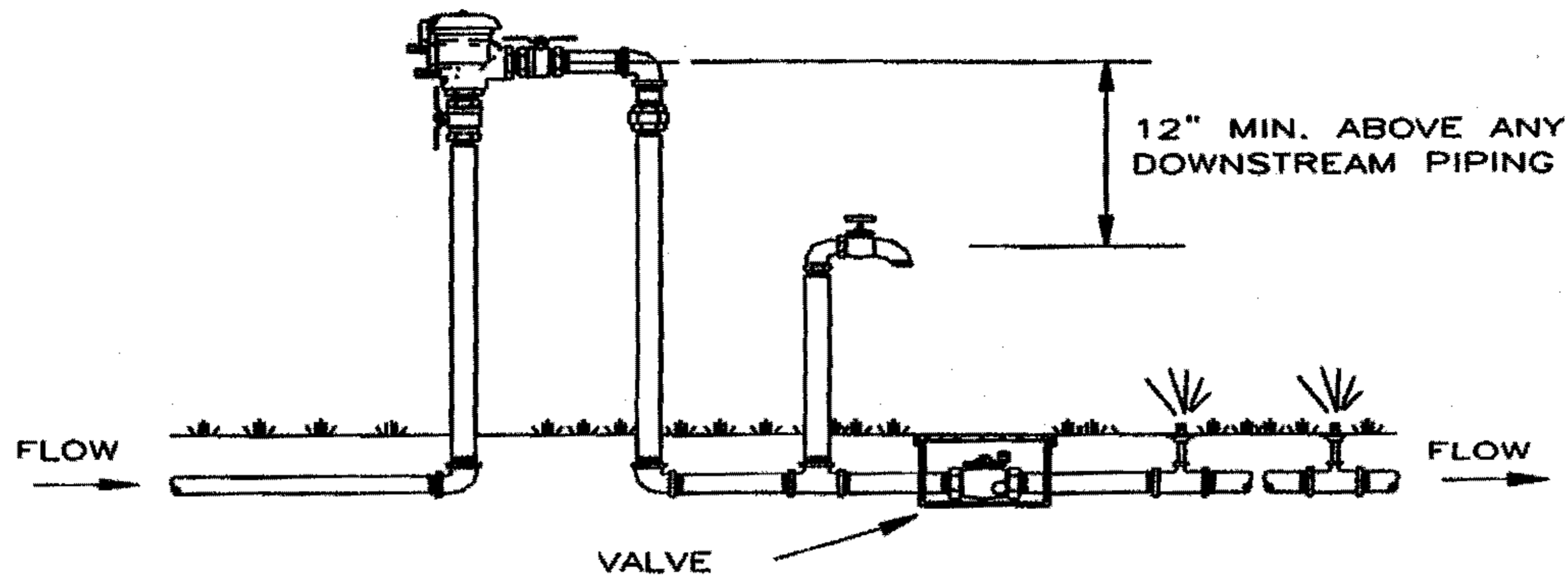

- (a) Be installed where occasional water discharge from the assembly caused by pressure fluctuations will not be objectionable;
 - (b) Have adequate spacing available for maintenance and testing;
 - (c) Not be subject to flooding;
 - (d) Be installed a minimum of 12 inches above the highest downstream piping and outlets;
 - (e) Have absolutely no means of imposing backpressure by a pump or other means. The downstream side of the PVB or SVB may be maintained under pressure by a valve; and
 - (f) Be used to protect against backsiphonage only, not backpressure.
- (10) An Atmospheric Vacuum Breaker (AVB) shall:

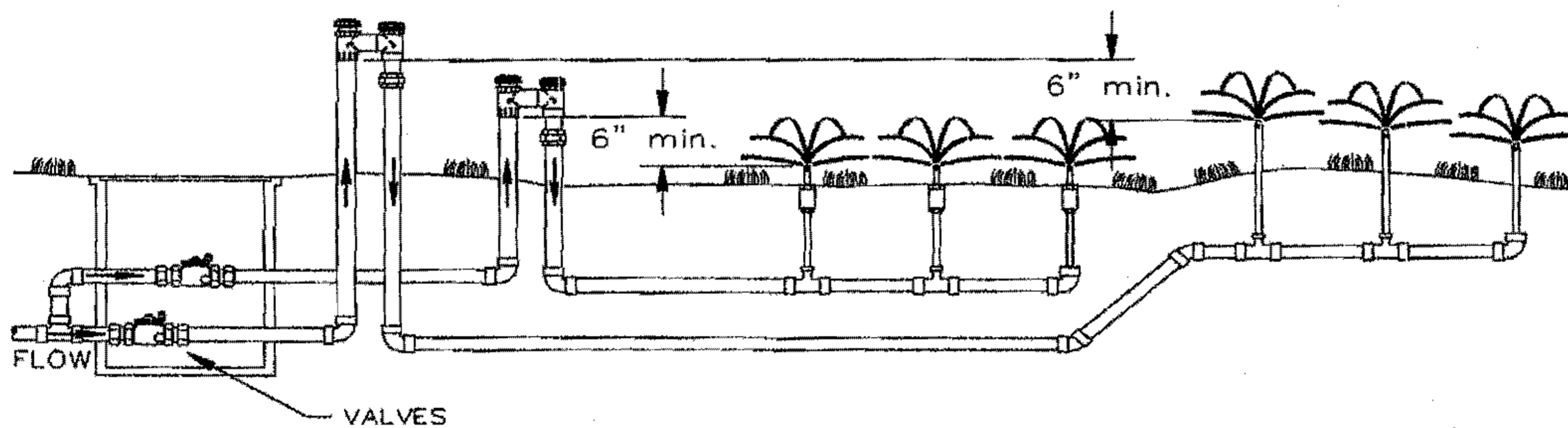

- (a) Have absolutely no means of shut-off on the downstream or discharge side of the AVB;
- (b) Not be installed in dusty or corrosive atmospheres;
- (c) Not be installed where subject to flooding;
- (d) Be installed a minimum of six inches above the highest downstream piping and outlets;
- (e) Be used intermittently;
- (f) Have product and material approval under the Oregon Plumbing Specialty Code for non-testable devices.
- (g) Not be pressurized for more than 12 hours in any 24-hour period; and
- (h) Be used to protect against backsiphonage only, not backpressure.

Stat. Auth.: ORS 448.131

Stats. Implemented: ORS 448.131, 448.150, 448.273 & 448.279