

April 14, 2020

Tom Ferrell, PE
 PACE Engineers, Inc.
 4500 Kruse Way, Suite 250
 Lake Oswego, OR 97035-2564

**Re: Crystal Springs Water District (PWS ID #00386)
 West Side Reservoir & Waterlines Phase 2 (PACE Project #17816)
 Conditional Approval – Plan Review #55-2020**

Dear Mr. Ferrell,

I have completed my review of the submitted plans and geotechnical report (received on April 3, 2020) along with a check for \$4,125 (received April 10, 2020) for waterlines and a 570,000 gallon prestressed concrete reservoir to be constructed on the west side of the Crystal Springs Water District (CSWD) near Odell. Since the waterlines are covered under CSWD’s existing Waterline Exemption, waterline plans were not reviewed and \$825 of the \$4,125 already submitted has been re-assigned to plan review #56-2020 for future submittal of plans involving the construction of an 830,000-gallon pre-stressed reservoir to be located on the south end of CSWD near Dog River Road.

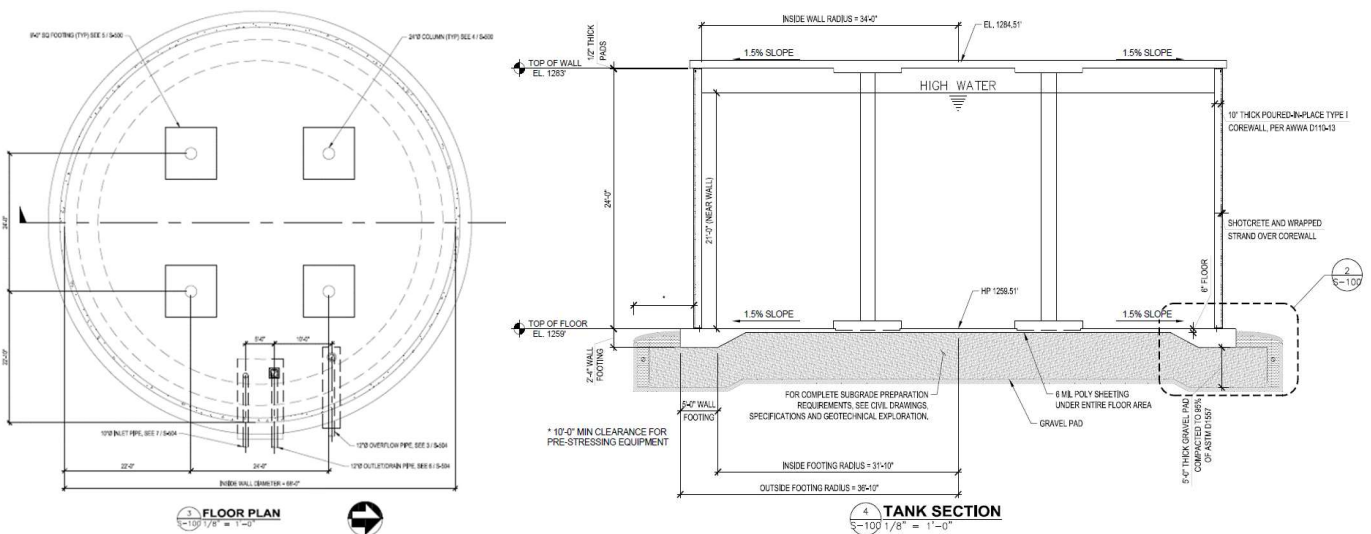

The project is approved for construction as shown in the submitted plans, provided the following conditions are met:

1. An access manhole shall be provided to permit entry to the interior for cleaning and maintenance. When the access manhole is on the roof of the reservoir there shall be a curbing around the opening and a lockable, watertight cover that overlaps the curbing [OAR 333-061-0050(6)(J)]. The proposed hatch does not appear to meet this requirement as shown below:

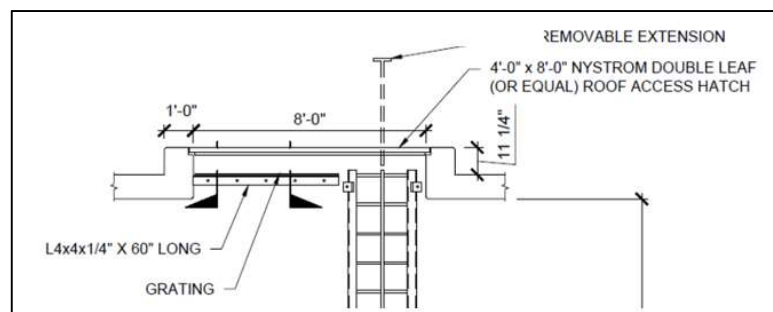
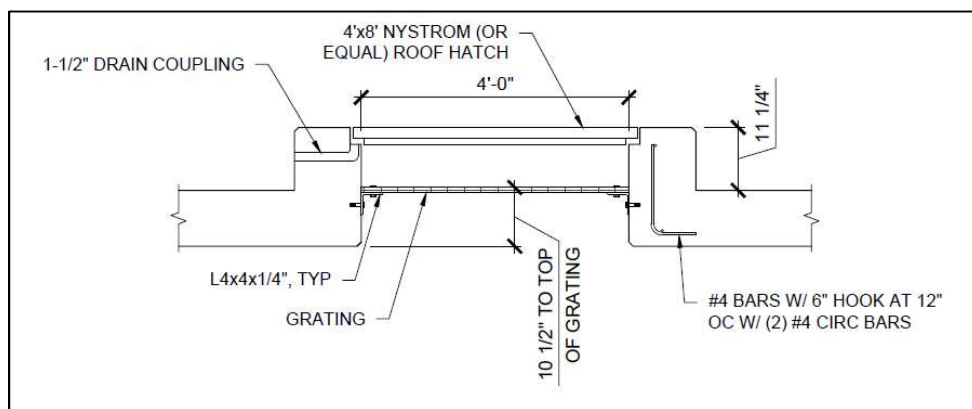

2. Should the interior surface of the finished water storage tank be provided with a protective coating, the coating shall meet the requirements of NSF Standard 61: Drinking Water System Components - Health Effects or equivalent [OAR 333-061-0050(6)(Q)].

These conditions are included among construction standards for reservoirs beginning on page 19 of OAR 333-061-0050 on-line at:

<https://www.oregon.gov/oha/PH/HEALTHYENVIRONMENTS/DRINKINGWATER/RULES/Documents/61-0050.pdf>

Crystal Springs Water District (PWS #00386) West Side Reservoir & Waterlines Ph 2 (PACE #17816)
Conditional Approval (PR#55-2020)
April 14, 2020

When the project is complete, please respond if the project was completed as planned and according to the conditions listed above. Correspondence may be in the form of a letter, via e-mail, or using our check list we will mail to you in about 6 months. Written correspondence should reference plan review #55-2020 and water system ID #00386 for the the Crystal Springs Water District and can be either e-mailed to me at evan.e.hofeld@state.or.us or mailed to:

Attn: Evan Hofeld
OHA-Drinking Water Services
PO Box 14450
Portland, OR 97293-0350

Until we receive verification that the project was completed with the conditions listed above met and we have granted Final Approval for the project, the reservoir is not approved for use. If you have any questions or would like this information in an alternate format, please feel free to contact me at any time at 971-673-0419 or via e-mail at evan.e.hofeld@dhsoha.state.or.us.

Sincerely,



Evan Hofeld, Regional Engineer
Oregon Health Authority – Drinking Water Services

Cc. Fredrick Schatz
Crystal Springs Water District
PO Box 187
Odell, OR 97044